

*Method.* Fill the viscometer through tube (*L*) with a sufficient quantity of the liquid to be examined, previously brought to 20 °C unless otherwise prescribed, to fill bulb (*A*) but ensuring that the level of liquid in bulb (*B*) is below the exit to ventilation tube (*M*). Immerse the viscometer in the bath of water at  $20 \pm 0.1$  °C, unless otherwise prescribed, maintain it in the upright position and allow to stand for not less than 30 min to allow the temperature to reach equilibrium. Close tube (*M*) and raise the level of the liquid in tube (*N*) up to a level about 8 mm above mark (*E*). Keep the liquid at this level by closing tube (*N*) and opening tube (*M*). Open tube (*N*) and measure, with a stop-watch to the nearest one-fifth of a second, the time required for the level of the liquid to drop from mark (*E*) to (*F*).

- $R_i$  = radius in metres of the inner cylinder,  
 $R_o$  = radius in metres of the outer cylinder,  
 $k$  = constant of the apparatus, expressed in radians per cubic metre.

For non-Newtonian liquids it is indispensable to specify the shear stress ( $\tau$ ) or the shear rate ( $\gamma$ ) at which the viscosity is measured. Under narrow gap conditions (conditions satisfied in absolute viscometers), there is a proportional relationship between  $M$  and  $\tau$  and also between  $\omega$  and  $\gamma$ :

$$\tau = AM \quad \gamma = B\omega$$

where A and B are constants for the instrument and are calculated from the following expressions:

– for concentric surface:

01/2008:20210

$$A = \frac{1}{4\pi h} \frac{R_i^2 + R_o^2}{R_i^2 R_o^2} \quad B = \frac{R_i^2 + R_o^2}{R_o^2 - R_i^2}$$

– for cone-plates:

$$A = \frac{3}{2\pi R^3} \quad B = \frac{1}{\alpha}$$

## 2.2.10. VISCOSITY - ROTATING VISCOMETER METHOD

The principle of the method is to measure the force acting on a rotor (torque) when it rotates at a constant angular velocity (rotational speed) in a liquid. Rotating viscometers are used for measuring the viscosity of Newtonian (shear-independent viscosity) or non-Newtonian liquids (shear dependent viscosity or apparent viscosity). Rotating viscometers can be divided in 2 groups, namely absolute and relative viscometers. In absolute viscometers the flow in the measuring geometry is well defined. The measurements result in absolute viscosity values, which can be compared with any other absolute values. In relative viscometers the flow in the measuring geometry is not defined. The measurements result in relative viscosity values, which cannot be compared with absolute values or other relative values if not determined by the same relative viscometer method.

Different measuring systems are available for given viscosity ranges as well as several rotational speeds.

- $M$  = torque in Newton-metres acting on the cone or cylinder surface,  
 $\omega$  = angular velocity in radians per second,  
 $R_i$  = radius in metres of the inner cylinder,  
 $R_o$  = radius in metres of the outer cylinder,  
 $R$  = radius in metres of the cone,  
 $h$  = height of immersion in metres of the inner cylinder in the liquid medium,  
 $\alpha$  = angle in radians between the flat disk and the cone,  
 $\tau$  = shear stress in pascals (Pa),  
 $\gamma$  = shear rate in reciprocal seconds ( $s^{-1}$ ).

### APPARATUS

The following types of instruments are most common.

#### CONCENTRIC CYLINDER VISCOMETERS (ABSOLUTE VISCOMETERS)

In the concentric cylinder viscometer (coaxial double cylinder viscometer or simply coaxial cylinder viscometer), the viscosity is determined by placing the liquid in the gap between the inner cylinder and the outer cylinder. Viscosity measurement can be performed by rotating the inner cylinder (Searle type viscometer) or the outer cylinder (Couette type viscometer), as shown in Figures 2.2.10-1 and 2.2.10-2, respectively. For laminar flow, the viscosity (or apparent viscosity)  $\eta$  expressed in pascal-seconds is given by the following formula:

$$\eta = \frac{1}{\omega} \left( \frac{M}{4\pi h} \right) \left( \frac{1}{R_i^2} - \frac{1}{R_o^2} \right) = k \frac{M}{\omega}$$

- $M$  = torque in newton-metres acting on the cylinder surface,  
 $\omega$  = angular velocity in radians per second,  
 $h$  = height of immersion in metres of the inner cylinder in the liquid medium,

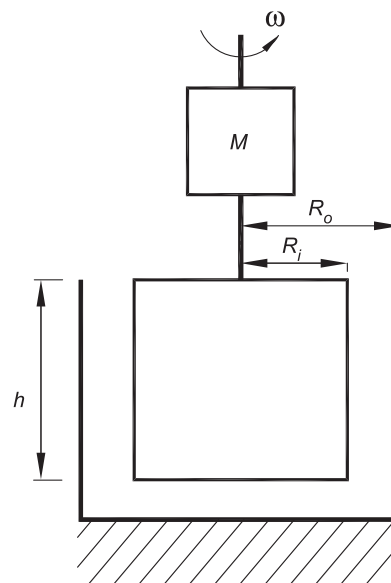

Figure 2.2.10-1

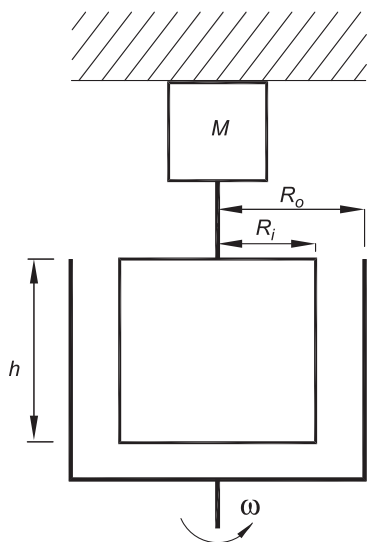

Figure 2.2.10.-2

**CONE-PLATE VISCOMETERS (ABSOLUTE VISCOMETERS)**

In the cone-plate viscometer, the liquid is introduced into the gap between a flat disc and a cone forming a define angle. Viscosity measurement can be performed by rotating the cone or the flat disc, as shown in Figures 2.2.10.-3 and 2.2.10.-4, respectively. For laminar flow, the viscosity (or apparent viscosity)  $\eta$  expressed in pascal-seconds is given by the following formula:

$$\eta = \left(\frac{M}{\omega}\right) \left(\frac{3\alpha}{2\pi R^3}\right) = k \frac{M}{\omega}$$

- $M$  = torque in Newton-metres acting on the flat disc or cone surface,
- $\omega$  = angular velocity in radians per second,
- $\alpha$  = angle in radians between the flat disc and the cone,
- $R$  = radius in metres of the cone,
- $k$  = constant of the apparatus, expressed in radians per cubic metre.

Constants  $A, B$  of the apparatus (see under concentric cylinder viscometers).

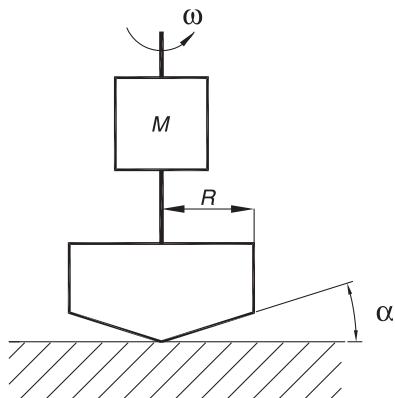

Figure 2.2.10.-3

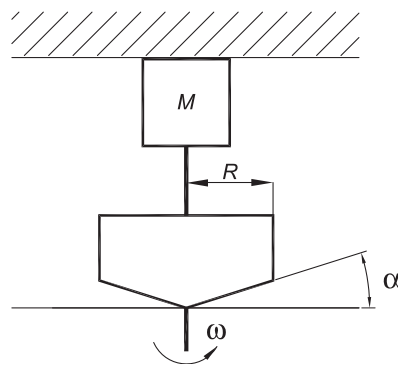

Figure 2.2.10.-4

**SPINDLE VISCOMETERS (RELATIVE VISCOMETERS)**

In the spindle viscometer, the viscosity is determined by rotating a spindle (for example, cylinder- or disc-shaped, as shown in Figures 2.2.10.-5 and 2.2.10.-6, respectively) immersed in the liquid. Relative values of viscosity (or apparent viscosity) can be directly calculated using conversion factors from the scale reading at a given rotational speed.

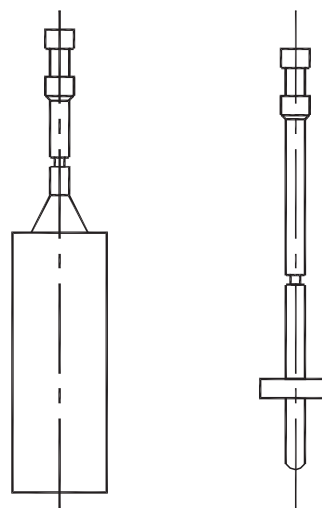

Figure 2.2.10.-5

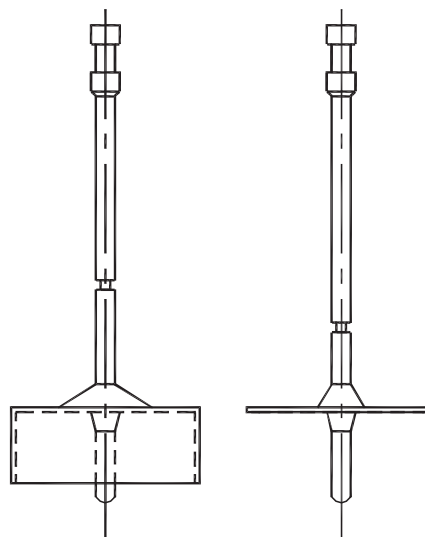

Figure 2.2.10.-6

In a general way, the constant  $k$  of the apparatus may be determined at various speeds of rotation using a certified viscometer calibration liquid. The viscosity  $\eta$  then corresponds to the formula:

$$\eta = k \frac{M}{\omega}$$

#### METHOD

Measure the viscosity (or apparent viscosity) according to the instructions for the operation of the rotating viscometer. The temperature for measuring the viscosity is indicated in the monograph. For non-Newtonian systems, the monograph indicates the type of viscometer to be used and if absolute viscometers are used the angular velocity or the shear rate at which the measurement is made. If it is impossible to obtain the indicated shear rate exactly, use a shear rate slightly higher and a shear rate slightly lower and interpolate.

With relative viscometers the shear rate is not the same throughout the sample and therefore it cannot be defined. Under these conditions, the viscosity of non-Newtonian liquids determined from the previous formula has a relative character, which depends on the type of spindle and the angular velocity as well as the dimensions of the sample container ( $\emptyset$  = minimum 80 mm) and the depth of immersion of the spindle. The values obtained are comparable only if the method is carried out under experimental conditions that are rigorously the same.

01/2008:20211

### 2.2.11. DISTILLATION RANGE

The distillation range is the temperature interval, corrected for a pressure of 101.3 kPa (760 Torr), within which a liquid, or a specified fraction of a liquid, distils in the following conditions.

**Apparatus.** The apparatus (see Figure 2.2.11-1) consists of a distillation flask (A), a straight tube condenser (B) which fits on to the side arm of the flask and a plain-bend adaptor (C) attached to the end of the condenser. The lower end of the condenser may, alternatively, be bent to replace the adaptor. A thermometer is inserted in the neck of the flask so that the upper end of the mercury reservoir is 5 mm lower than the junction of the lower wall of the lateral tube. The thermometer is graduated at 0.2 °C intervals and the scale covers a range of about 50 °C. During the determination, the flask, including its neck, is protected from draughts by a suitable screen.

**Method.** Place in the flask (A) 50.0 mL of the liquid to be examined and a few pieces of porous material. Collect the distillate in a 50 mL cylinder graduated in 1 mL. Cooling by circulating water is essential for liquids distilling below 150 °C. Heat the flask so that boiling is rapidly achieved and note the temperature at which the first drop of distillate falls into the cylinder. Adjust the heating to give a regular rate of distillation of 2-3 mL/min and note the temperature when the whole or the prescribed fraction of the liquid, measured at 20 °C, has distilled.

Correct the observed temperatures for barometric pressure by means of the formula:

$$t_1 = t_2 + k(101.3 - b)$$

- $t_1$  = the corrected temperature,
- $t_2$  = the observed temperature, at the barometric pressure  $b$ ,
- $k$  = the correction factor taken from Table 2.2.11-1 unless the factor is given,
- $b$  = the barometric pressure, expressed in kilopascals, during the distillation.

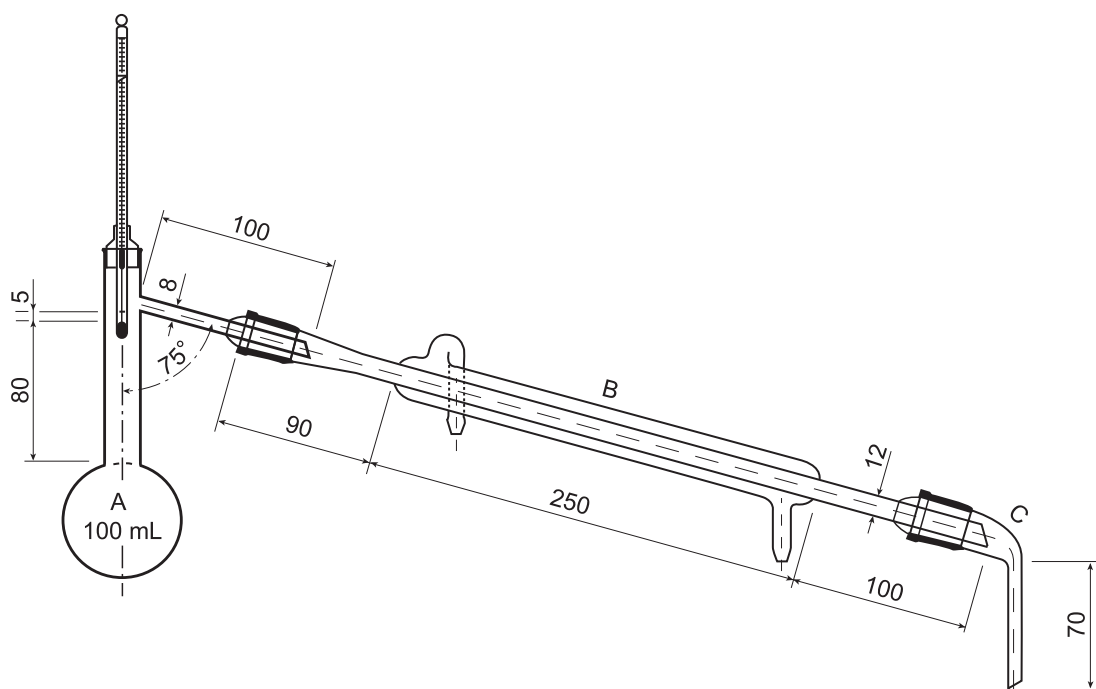

Figure 2.2.11-1. – Apparatus for the determination of distillation range

Dimensions in millimetres